



UD TRUCKS

Quon

UD 460 WT



ENGINE

Engine model:	UD Trucks GE 13 TD
Engine type:	Turbocharged intercooled, 6 cylinder in-line with 4-valve technology
Displacement:	13 074cm ³
Injection system:	Electronically controlled unit injectors
Maximum power output:	340kW @ 1800rpm
Maximum torque:	2256Nm @ 1200rpm
Filtration (Fuel):	Primary & secondary, secondary with water trap
Filtration (Oil):	Bypass oil filter

PTO

Location:	Optional – rear of transmission
-----------	---------------------------------

AIR CLEANER

Intake:	Raised behind cab
Model:	Donaldson FTG 15
Type:	Cyclonic, safety and primary paper elements

CLUTCH

Type:	Dry, single plate – self adjusting
Operation:	Hydraulic, air-assisted
Disc diameter:	430mm

TRANSMISSION

Model:	ZF-16S 221 OD
Type:	16-speed synchromesh
Controls:	Air-assisted, manual gearshift

BRAKES

Service brakes:	Dual circuit full air with EBS. Wedge-type, drum brakes all-round
Park brakes:	Spring brakes on front and rear axle
Auxiliary brakes:	Remote mounted exhaust brake with engine decompression
Auxiliary brakes (intarder type):	ZF Hydrodynamic intarder
Braking torque:	3500 Nm

FRONT AXLE

Type:	FF85 drop-forged "I" beam (reverse "Elliot" steering knuckles)
Suspension:	Taper leaf spring with double-acting telescopic shock absorbers
Stabiliser:	Fitted to front axle

REAR AXLE

Type:	RW1A dual-drive bogie with single reduction hypoid differentials and lockable inter-axle differential
Suspension:	Trunnion-mounted inverted semi-elliptic multi leaf springs

WHEELS AND TYRES

Rims:	9.00 X 22.5 – 175 single-piece steel discs
Tyres:	Tubeless radials Front 315/80 R22.5 Rear 315/80 R22.5
Spare wheel mounting:	Temporary mounted on 5th wheel
Size:	315/80 R22.5
Optional extra:	385/65 R22.5 front tyres only

STEERING

Type:	Recirculating ball, power assisted
No of turns lock to lock:	5

CHASSIS

Type:	High tensile, reinforced parallel ladder frame
Frame section (Main):	300mm X 85mm X 8mm

FUEL TANK

Primary:	400ℓ, Aluminium
Secondary:	200ℓ, Aluminium
Feature:	Lockable fuel cap

ELECTRICAL SYSTEM

Alternator:	24 V, 60 A
Starter motor:	24 V, 7 kW
Batteries:	2 X 12 V, 118 Ah,
System voltage:	24 V (negative)

CAB

- G300 steel/composite forward control
- 4-point air suspension with shock absorbers
- Full trim interior with cover for rear window
- Adjustable steering column for height and rake
- Single sleeper compartment with under bed storage, wardrobe and mattress
- Manually adjustable air conditioner
- Radio/CD-player
- Centre overhead parcel box
- Adjustable air suspended driver's seat, including lumbar support and integral headrest
- Fixed assistant seat – fold-up type with integral headrest
- 3-point ELR driver and assistant safety belt
- Heater/Demister (4-speed blower)
- Cigarette lighter
- Column-mounted lever for lights, indicators, windscreen wipers/washers, hazard warning, exhaust brake/ "extra" engine brake

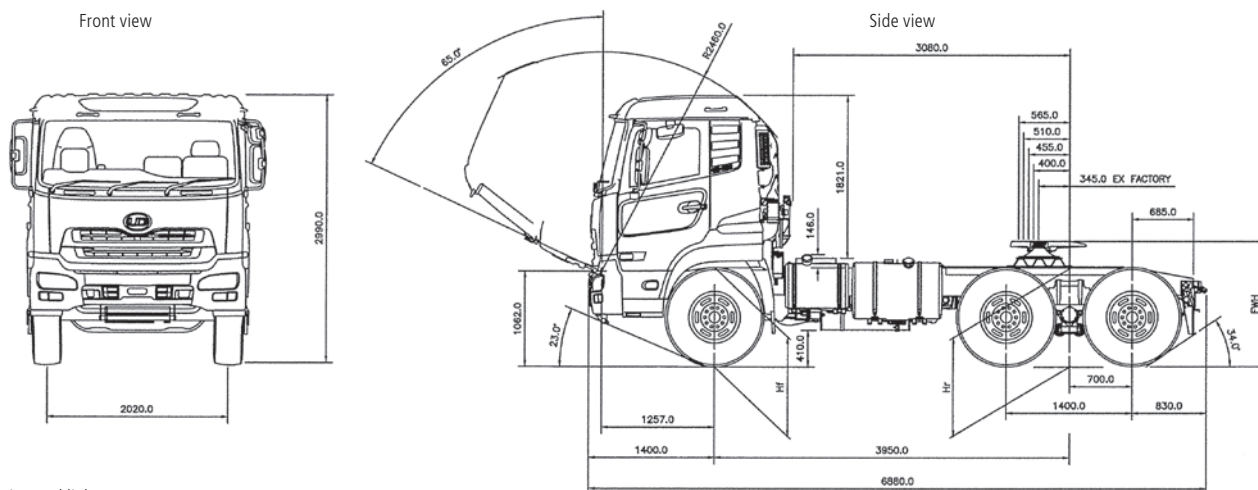

- Fluorescent internal light
- 2 Sun visors with document holders
- Door side pockets
- Electrically operated windows
- 3 Windscreen wipers (2 speeds + intermittent setting) (washer reservoir 4.7ℓ)
- Fog lamps
- 4 External rear-view mirrors (Wide Angle mirrors on LHS) Body width – 2.6m
- Step lamps driver side
- Aluminium cab steps
- Central door locking – with key
- All-round curtains fitted inside cab
- Hand trailer control brake with auto return function
- Cab step & grip Handle for access to rear of cab
- Rear working light
- 2 Cup holders
- Speed limiter standard – 90km/h, options 80, 100, 110 km/h
- Headlight height adjustment from inside the cab

INSTRUMENTS

Speedometer, odometer, tripmeter, rev counter, fuel gauge, dual air pressure gauge, engine water temperature gauge. Audio and visual warning devices

PERFORMANCE DATA

Final drive ratio: 4.625

MASS INFORMATION

Tare mass chassis/cab:	8 550 Kg
Tare mass on front axle:	4 480 Kg
Tare mass on rear axle/bogie:	4 070 Kg
Manufacturer's gross front axle massload (GA):	8 500 Kg
Manufacturer's gross rear axle and massload (GA/GAU):	21 000 Kg

Manufacturer's gross vehicle mass (GVM):	26 000 Kg
Manufacturers gross combination mass (GCM):	65 000 Kg
Max permissible front: axle massload (A)	7 500 Kg
Max permissible rear/unit massload (A/AU):	18 000 Kg
Max permissible vehicle mass (V):	25 500 Kg
Max permissible drawing vehicle mass (D/T):	65 000 Kg

DIMENSIONS

Wheelbase (WB):	3 950 mm
Overall length (OL):	6 880 mm
Overall width (OW):	2 515 mm
Overall height (OH):	2 990 mm
Frame height unladen (front):	1 019 mm
Frame height unladen (rear):	1 110 mm
Ground clearance (rear):	250 mm
Track front (FT):	2 020 mm
Track rear (RT):	1 840 mm
Overhang front (FO):	1 400 mm
Overhang rear (ROF)(to end of frame):	830 mm
Centre of rear axles to rear of cab (CA):	3 080 mm
Chassis width:	840 mm
Cab tilt angle:	65 degrees
Turning circle:	17 000 mm
Max allowable fifth wheel offset:	565 mm

MISCELLANEOUS EQUIPMENT

Jack, warning triangle & basic tool kit, owner's handbook/service booklet
 Jost JSK 37C fifth wheel, rear chevron board and brake/electrical trailer couplings
 PTO failsafe controls (parkbrake "ON" allows for PTO operation)
 Engine "fast heat" switch, governor control lever (optional), chassis mounted toolbox

PERFORMANCE DATA

Gear	Gear Ratio :1	Road Speed @ Max R/Min (Km/H)	Road Speed @ Max Torque (Km/H)	Gradeability @ V %	Gradeability @ D/T %
1ST	13.800	6	4	90.88%	42.19%
2ND	11.510	7	4	75.80%	35.19%
3RD	9.590	9	5	63.15%	29.32%
4TH	8.020	11	6	52.81%	24.52%
5TH	6.810	13	8	44.85%	20.82%
6TH	5.700	15	9	37.54%	17.43%
7TH	4.580	19	11	30.16%	14.00%
8TH	3.840	22	13	25.29%	11.74%
9TH	3.010	28	17	19.82%	9.20%
10TH	2.520	34	20	16.60%	7.70%
11TH	2.090	41	25	13.76%	6.39%
12TH	1.750	49	29	11.52%	5.35%
13TH	1.490	57	34	9.81%	4.56%
14TH	1.240	69	41	8.17%	3.79%
15TH	1.000	85	51	6.59%	3.06%
16TH	0.840	102	61	5.53%	2.57%
Rev	12.920	7	4	85.08%	39.50%
Rev	10.800	8	5	71.12%	33.02%

The contents are not binding and are for guidance only. Improvements and/or design changes may alter specifications. Dimensions and masses are subject to manufacturing tolerances. Illustrations may depict options or non-standard equipment.