



UD TRUCKS

UD 40 A

M02



ENGINE

Engine model:	UD Trucks TD42T
Engine type:	Turbo charged, 6 cylinder in-line, water cooled
Displacement:	4 169 cm ³
Injection system:	Indirect injection - Euro II compliant
Maximum power output:	87kW @ 3250 r/min
Maximum torque:	275Nm @ 2000 r/min
Filtration - Fuel:	Primary & secondary, secondary with water-trap
Filtration - Oil:	Two cartridge filters on engine & one bypass, paper element filter

PTO – OPTIONAL

Location:	Transmission LHS
Operation:	Manual - via cable
Output:	Max. 200Nm @ 1000 Eng. rpm
Ratio:	93.1% of engine speed
Rotational direction:	Counterclock as seen from rear
Pump mounting:	Direct - SAE 3 hole
Pump connection:	ISO 14

AIR CLEANER

Intake:	Raised behind cab
Model:	Donaldson FRG 9"
Type:	Cyclonic, safety & primary paper elements
Service indicator:	Progressive type mounted on air cleaner

CLUTCH

Type:	Dry, single plate - D300K
Operation:	Hydraulic - self adjusting
Disc diameter:	300mm
Total friction area:	846 cm ²

TRANSMISSION

Model:	UD Trucks MES50C
Type:	5-speed synchromesh
Controls:	Manual gearshift
Ratios:	Refer to performance data

BRAKES

Service brakes:	Vacuum assisted dual line hydraulic drum brakes all round
Emergency/Park brakes:	Mechanical transmission-mounted drum brake
Auxiliary/Engine brakes:	Remote-mounted butterfly type exhaust brake

FRONT AXLE

Type:	Drop-forged "I" beam with reverse "Elliot" steering knuckles
Suspension:	Semi-elliptic steel leaf springs with telescopic shock absorbers

REAR AXLE

Type:	Fully floating pressed steel banjo type housing, single reduction, hypoid
Suspension:	Semi-elliptic steel leaf springs with telescopic shock absorbers

WHEELS & TYRES

Rims:	6.00GS x 16 SDC steel disc wheels
Tyres:	Tubed radials
Tyres:	Front: 7.50R x 16 - 12 PR (LT)
Tyres:	Rear: 7.50R x 16 - 12 PR (LT)
Spare wheel mounting:	Slung from a winch-type carrier mounted at the rear of the chassis
Spare wheel size:	7.50R x 16 - 12 PR (LT)

STEERING

Type:	Power assisted, recirculating ball
Ratio:	22:01
Number of turns lock to lock:	4.5

CHASSIS

Type:	High tensile, reinforced parallel ladder frame
Frame Section: Main:	180 x 60 x 4.5 mm

FUEL TANK

Primary:	100L - Steel
	Lockable fuel tank cap

ELECTRICAL SYSTEM

Alternator	24 V, 35 A
Starter motor	24 V, 3.5 kW
Batteries	2 x 12 V, 85 Ah (669P)
System voltage	24 V (Negative)

CAB

- Steel/composite forward control with 4-point suspension
- Adjustable driver's seat
- Fixed assistant's and centre seat
- Heater/demister (4-speed blower)
- Cigarette lighter

Front view

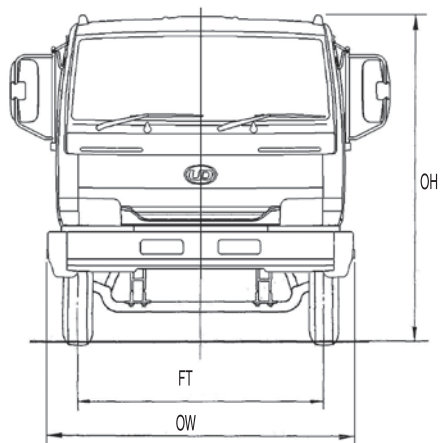

Side view

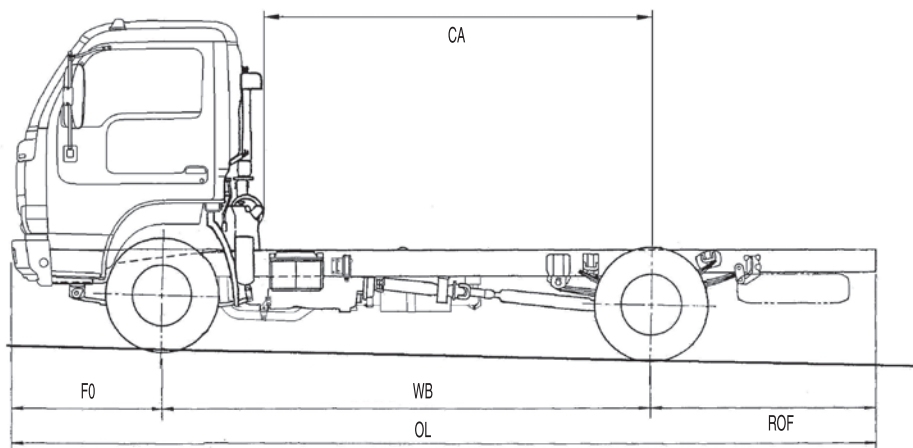

- Column-mounted lever for lights, indicators, windscreen wipers/washers, hazard warning, exhaust brake
- 2 Windscreen wipers (2 speeds + intermittent setting)
- 2 External rear-view mirrors

INSTRUMENTS

Speedometer, odometer, trip meter, rev counter, fuel gauge. Engine water temperature gauge and audio & visual warning devices

PERFORMANCE DATA

Final drive ratio 5.857

MASS INFORMATION

Tare mass chassis/cab (without fuel & driver, with tools & sparewheel)	2 300 kg
Tare mass on front axle	1 500 kg
Tare mass on rear axle	800 kg
Manufacturer's gross front axle massload (GA)	2 800 kg
Manufacturer's gross rear axle/unit mass load (GA/GAU)	5 500 kg
Manufacturer's gross vehicle mass (GVM)	7 000 kg
Manufacturer's gross combination mass (GCM)	8 500 kg
Max permissible front axle mass load (A)	2 800 kg
Max permissible rear/unit mass load (A/AU)	5 500 kg

Max permissible vehicle mass (V)	7 000 kg
Max permissible drawing vehicle mass (D/T)	8 500 kg

DIMENSIONS

Wheelbase (WB)	3 350 mm
Overall length (OL)	6 060 mm
Overall width (OW)	2 125 mm
Overall height (OH)	2 285 mm
Ground clearance	205 mm
Track front (FT)	1 665 mm
Track rear	1 540 mm
Overhang front (FO)	1 030 mm
Overhang rear (ROF) (to end of frame)	1 545 mm
Centre of rear axle to rear of cab (CA)	2 625 mm
Chassis width	750 mm
Cab tilt angle	40 degrees
Turning circle	12 600 mm

MISCELLANEOUS EQUIPMENT

4-ton jack, warning triangle, basic toolkit
Owner's handbook & service booklet
Rear chevron board

PERFORMANCE DATA

Gear	Gear ratio :1	Road speed @ max r/min (km/h)	Road speed @ max torque (km/h)	Gradeability @ v %	Gradeability @ d/t %
1st	5.099	17	10	26.09%	21.49%
2nd	3.006	29	17	15.38%	12.67%
3rd	1.638	53	30	8.38%	6.90%
4th	1.000	87	50	5.12%	4.21%
5th	0.752	116	66	3.85%	3.17%
Reverse	4.862	18	10	24.88%	20.49%

The contents are not binding and are for guidance only. Improvements and/or design changes may alter specifications. Dimensions and masses are subject to manufacturing tolerances. Illustrations may depict options or non-standard equipment.